

TFLEX - 42

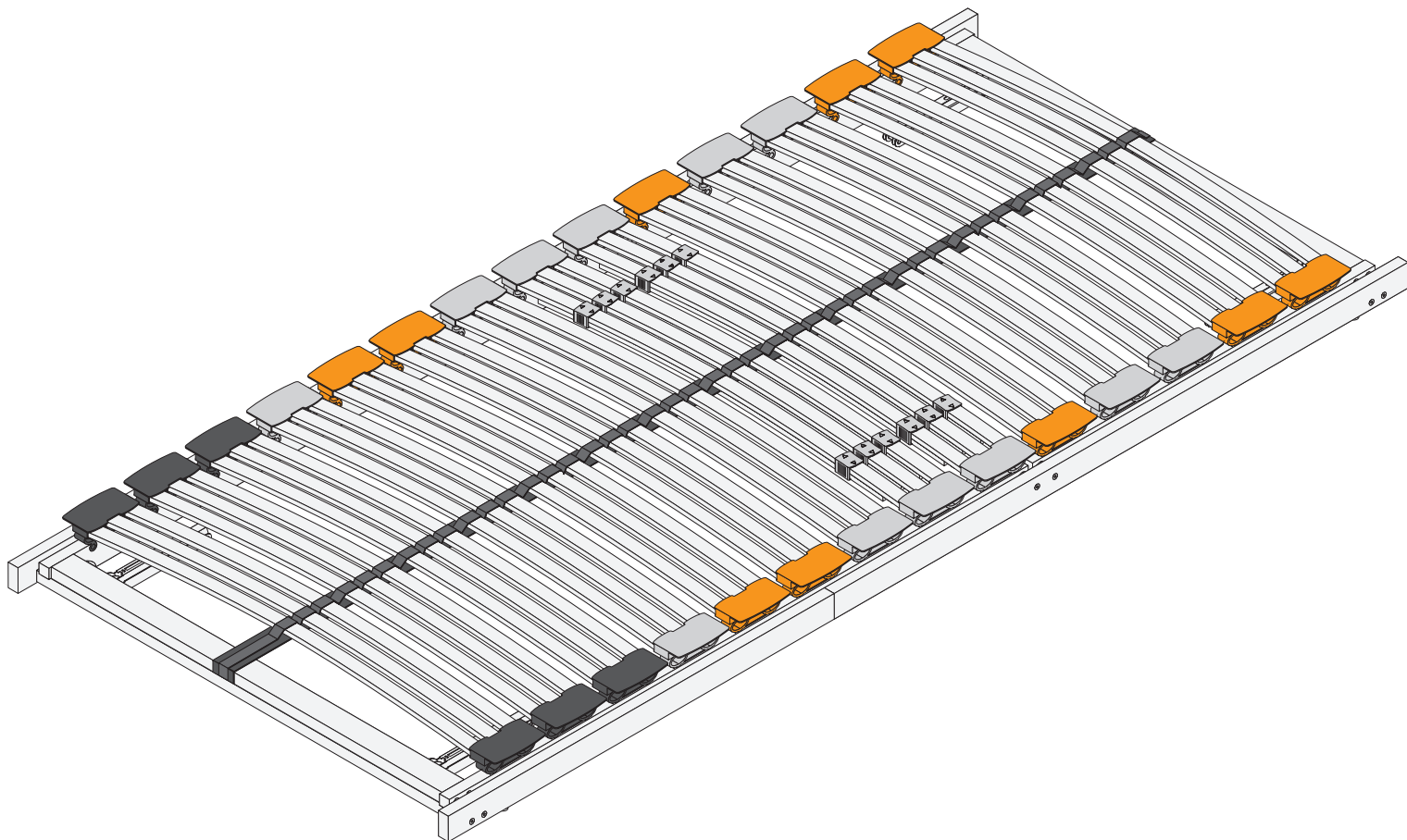

EASY ASSEMBLING IN 13 STEPS



MONTAGE : 1 oder 2 personen
ASSEMBLY : 1 or 2 persons
MONTAJE : 1 o 2 personas
MONTAGE : 1 ou 2 personnes
MONTAGEM : 1 ou 2 pessoas



MONTAGEZEIT : 1h
ASSEMBLY TIME : 1h
TIEMPO DE ENSAMBLAJE : 1h
TEMPS DE MONTAGE : 1h
TEMPO DE MONTAGEM : 1h

DE - ACHTUNG:

Um Beschädigungen des Bettrahmens zu vermeiden, überprüfen Sie bitte vor Beginn der Montage, ob **6 Auflagepunkte** am Bettrahmen vorhanden sind.

Jedes handelsübliche Lattenrost benötigt die abgebildeten Auflagepunkte.

EN - ATTENTION:

To avoid damage to the slatted bed frame, before starting the installation, please check that you have **6 support points** on the bed frame.

All slatted bed frames must have all supports as shown in the picture.

ES - ATENCIÓN:

Para evitar dañar el marco de la cama, compruebe antes de iniciar el ensamblaje que la estructura de la cama tiene **6 puntos de apoyo**.

Cualquier somier estándar requiere los puntos de soporte que aparecen en la imagen.

FR - ATTENTION:

Pour éviter d'endommager le cadre du lit, veuillez vérifier, avant de commencer le montage, que votre structure de lit dispose bien de **6 points d'appui**.

Tout sommier à lattes, nécessite les points d'appui représentés sur l'image.

IT - ATTENZIONE:

Per evitare danni al giroletto, prima di iniziare l'installazione assicurarsi di avere **6 punti di appoggio** sul giroletto. **Tutti i mazzi devono avere punti di appoggio come mostrato nell'immagine.**

PT - ATENÇÃO:

Para evitar danos no estrado da cama, antes de iniciar a instalação, verifique se você tem **6 pontos de suporte** na estrutura da cama.

Todos os estrados devem ter os pontos de suporte tal como ilustrado na imagem.

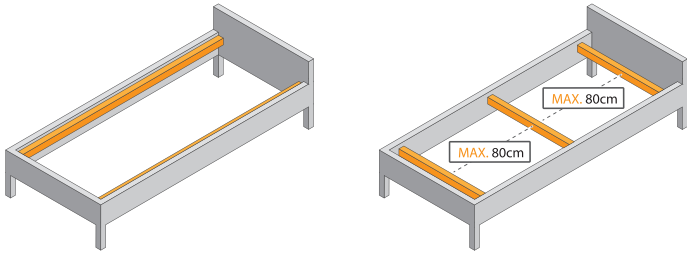
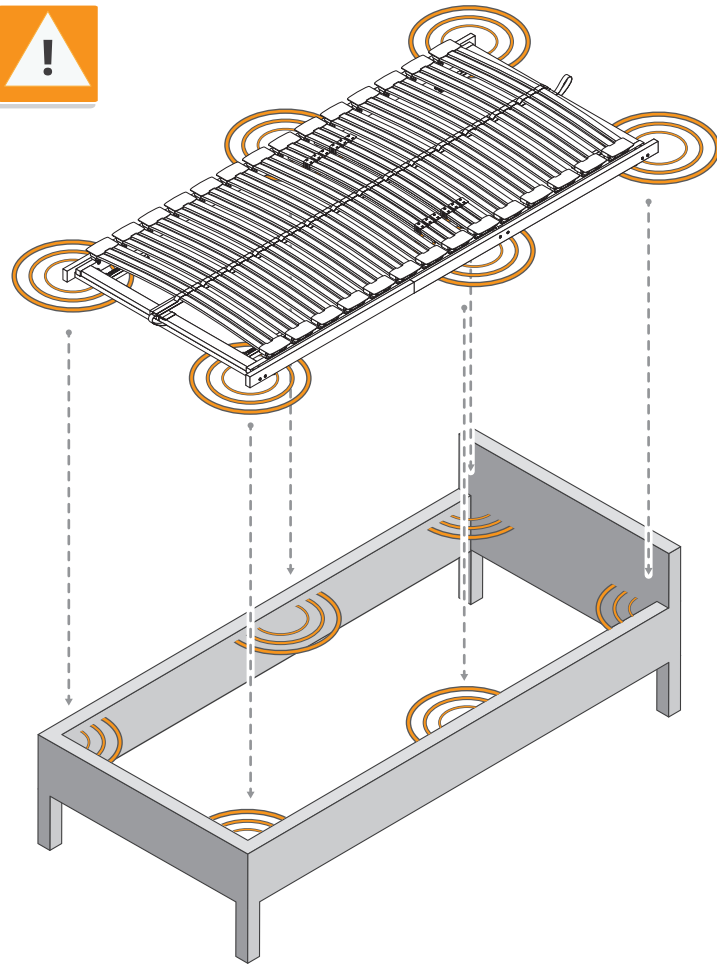

TEILE UND WERKZEUGE | PARTS AND TOOLS | PIEZAS Y HERRAMIENTAS | PIÈCES ET OUTILS | PARTI E UTENSILI | PEÇAS E FERRAMENTAS

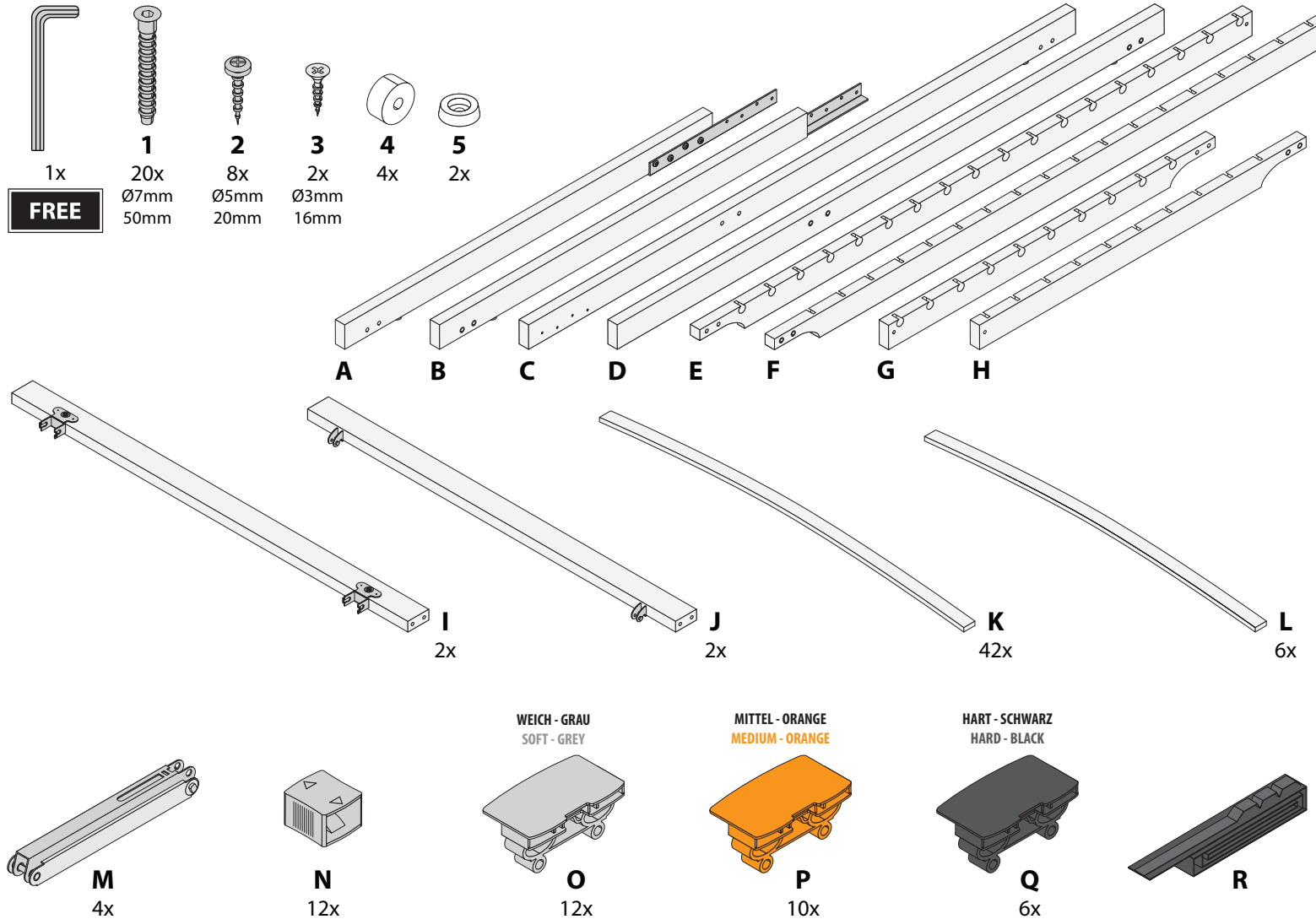

1

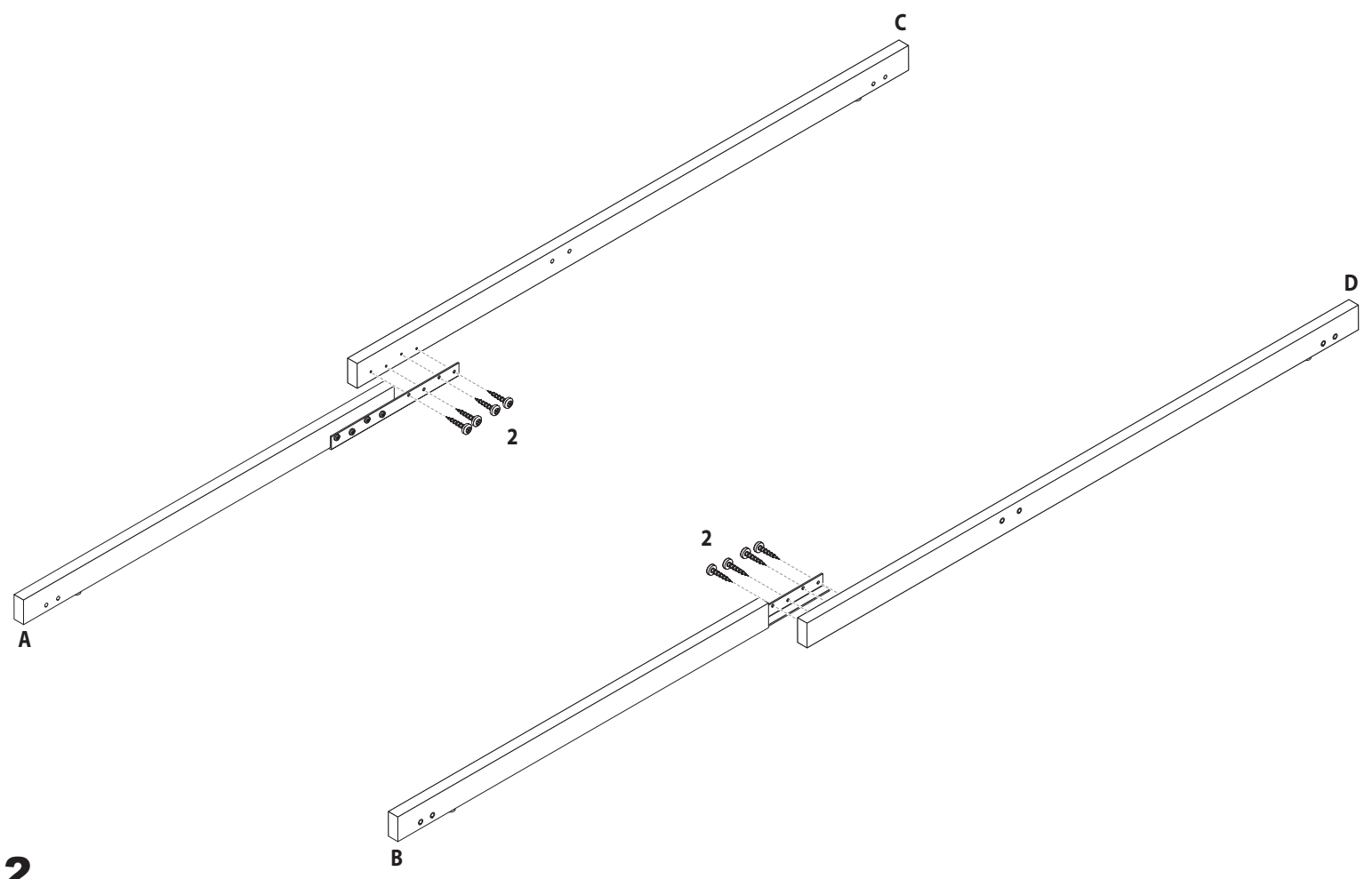

2

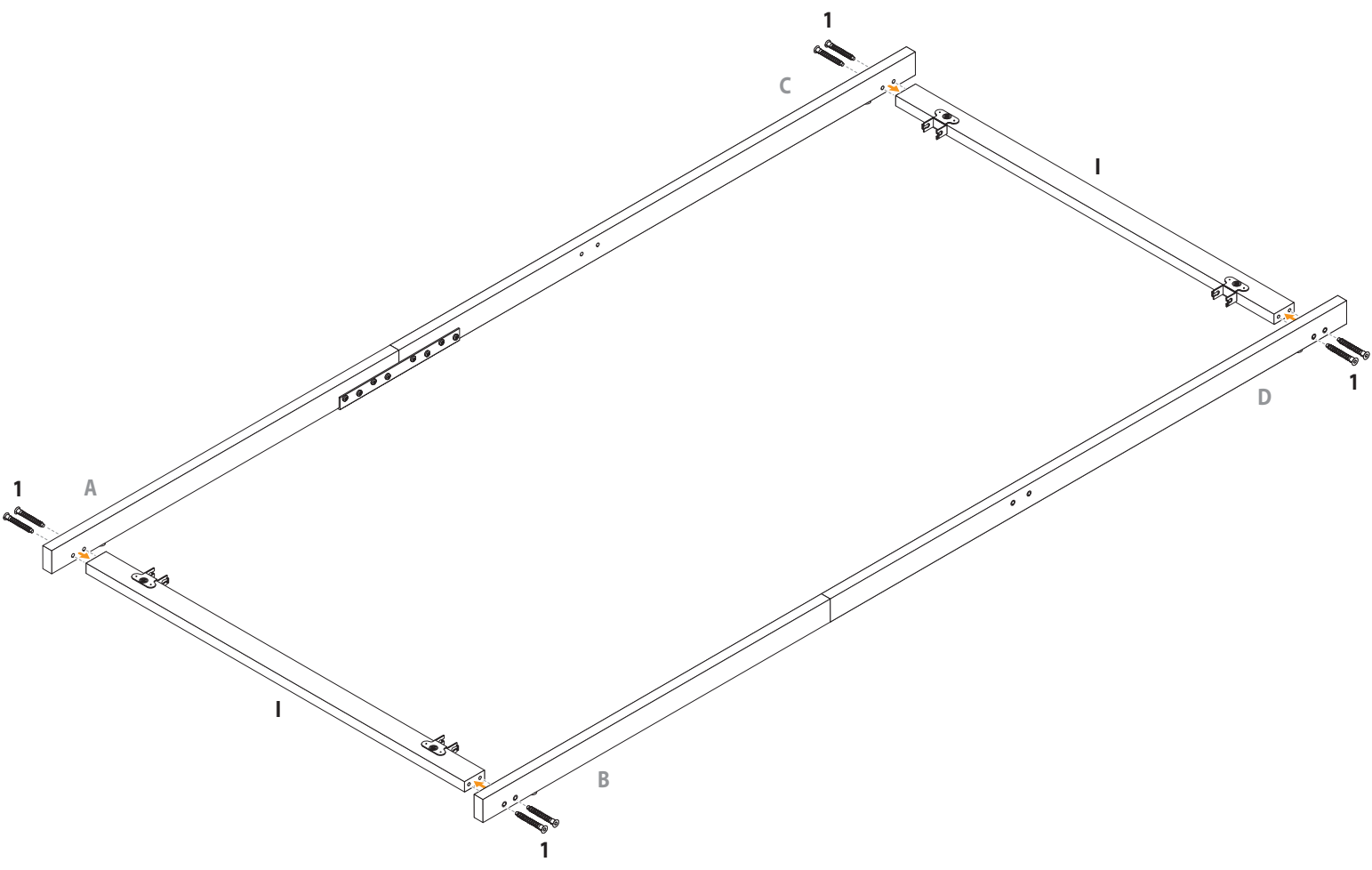

3

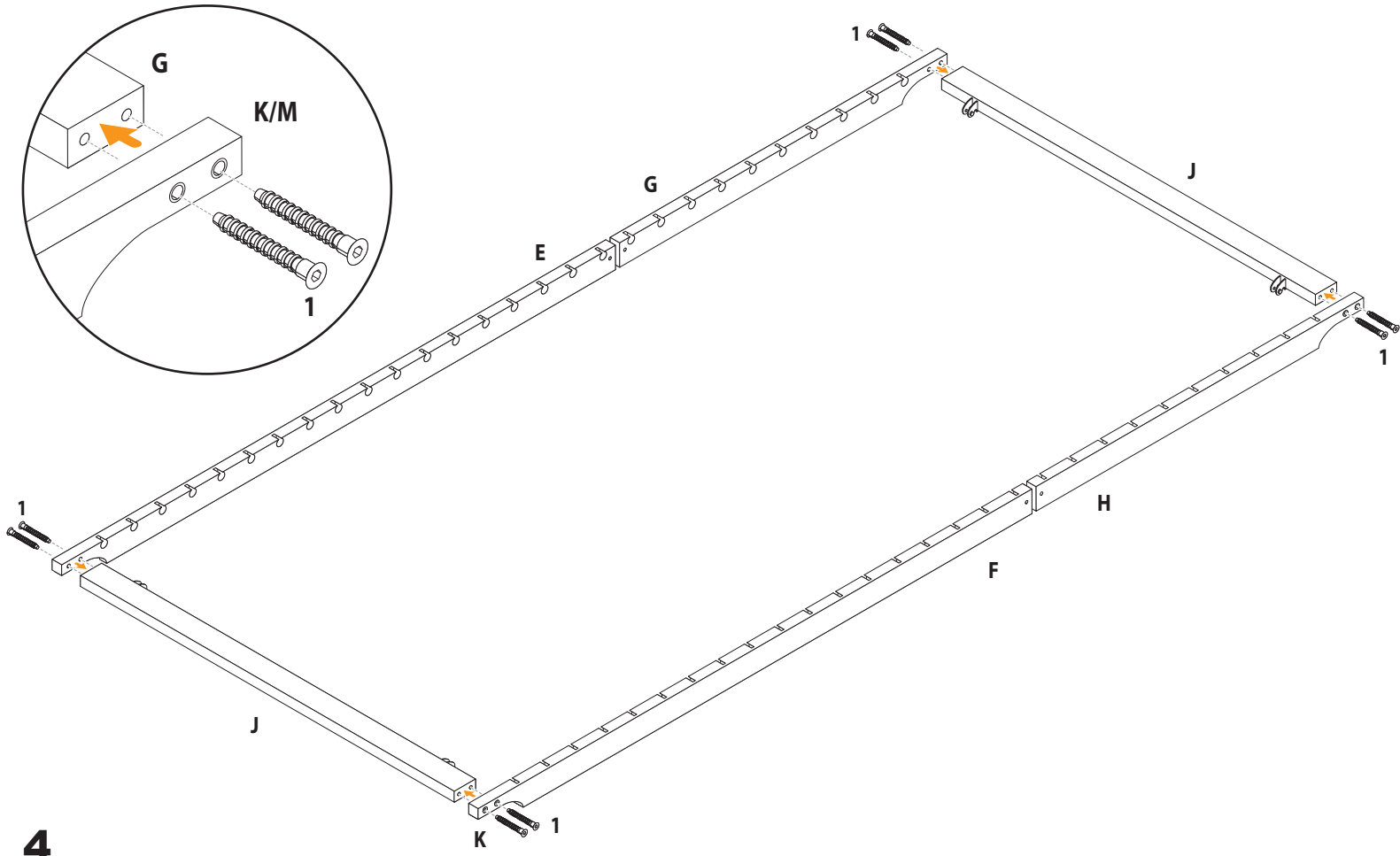

4

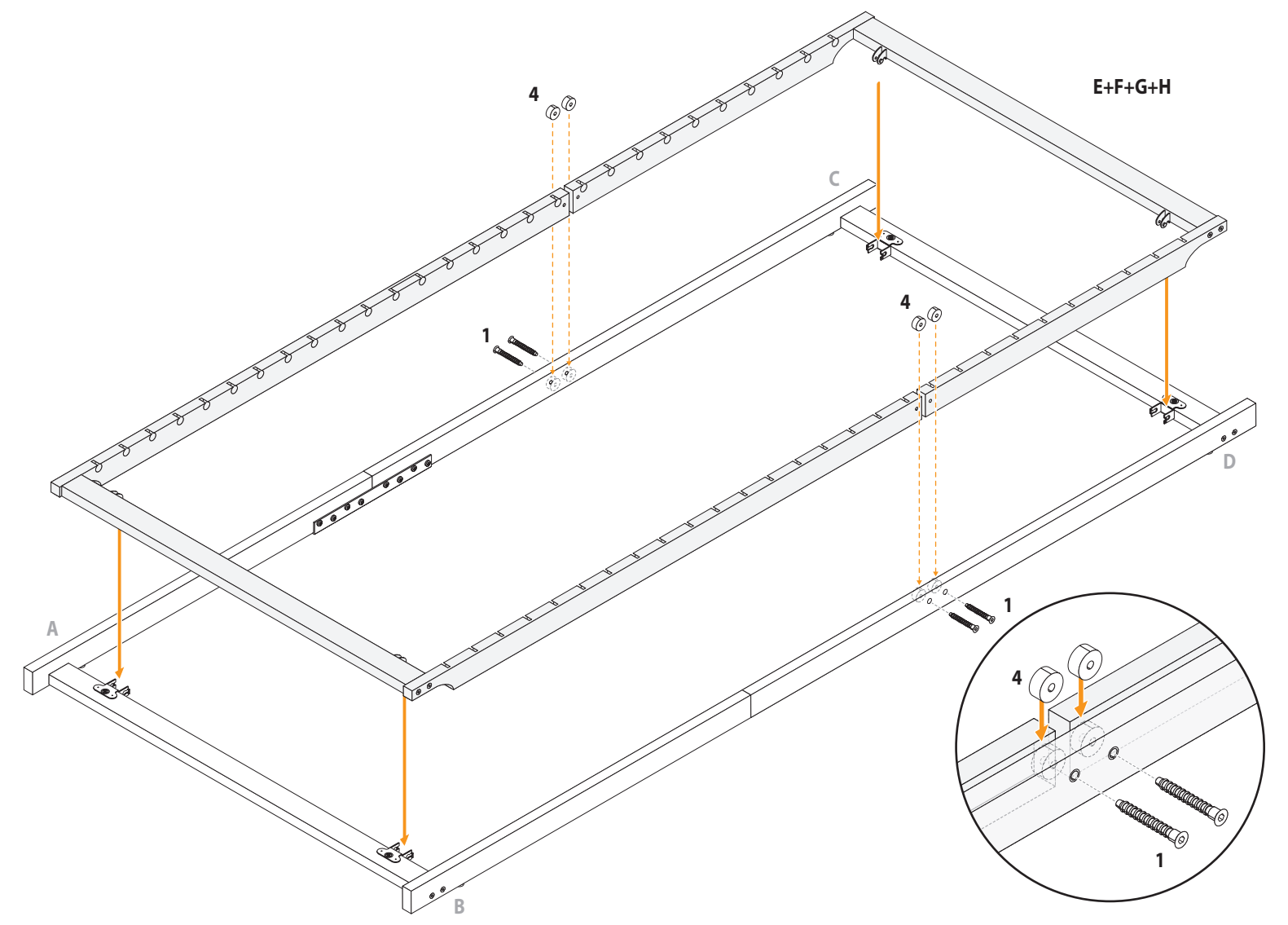

7

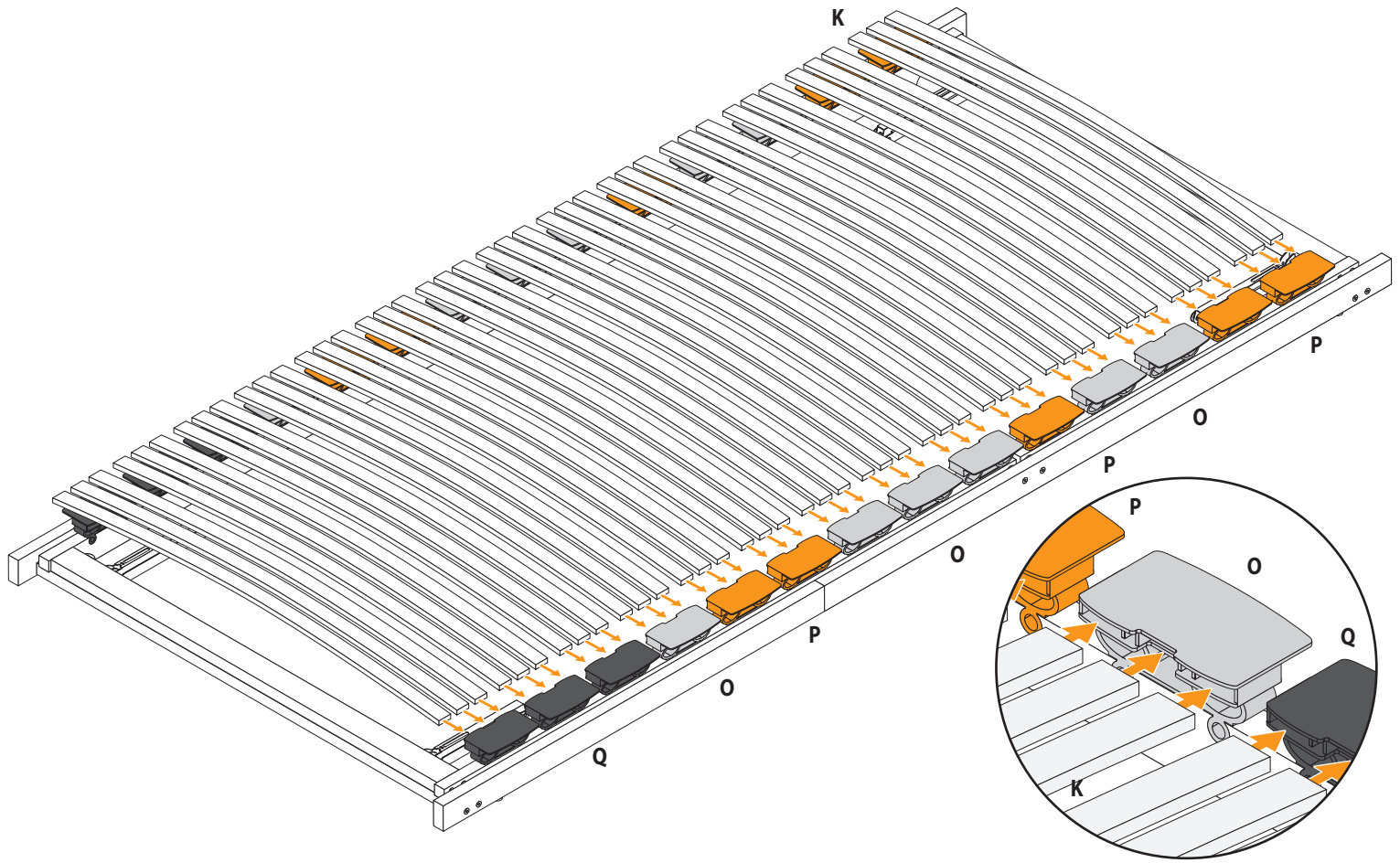

8

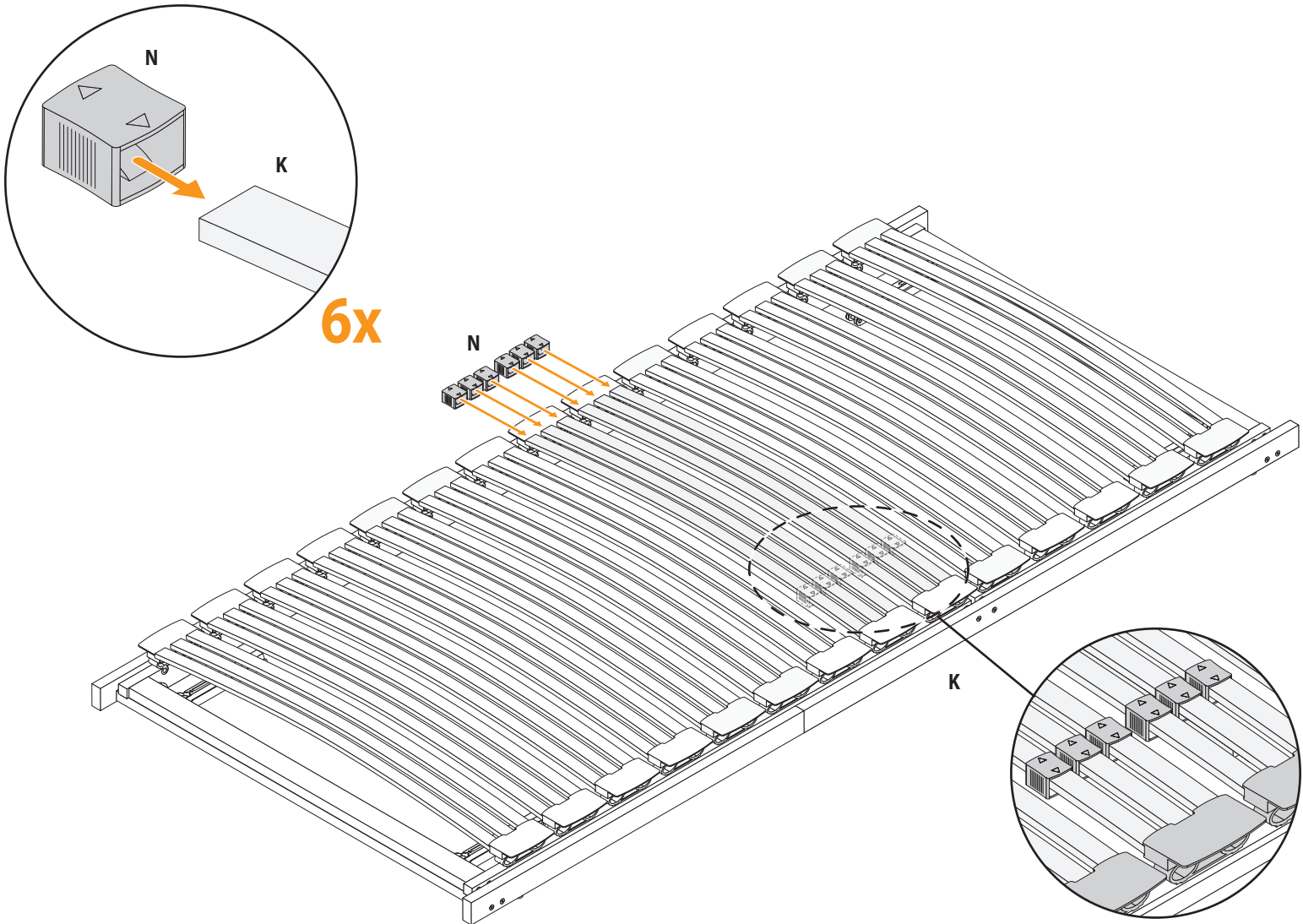

9

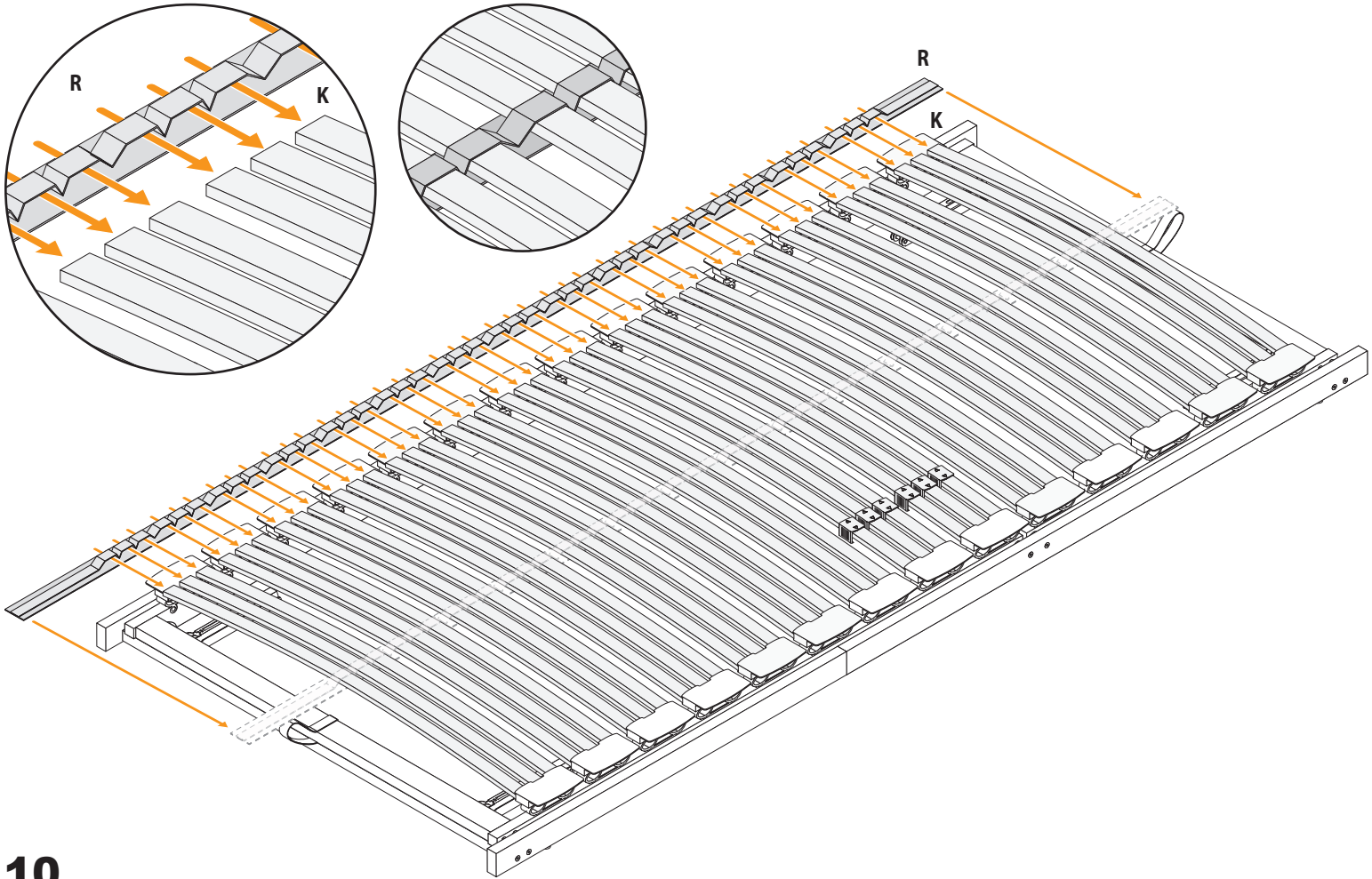

10

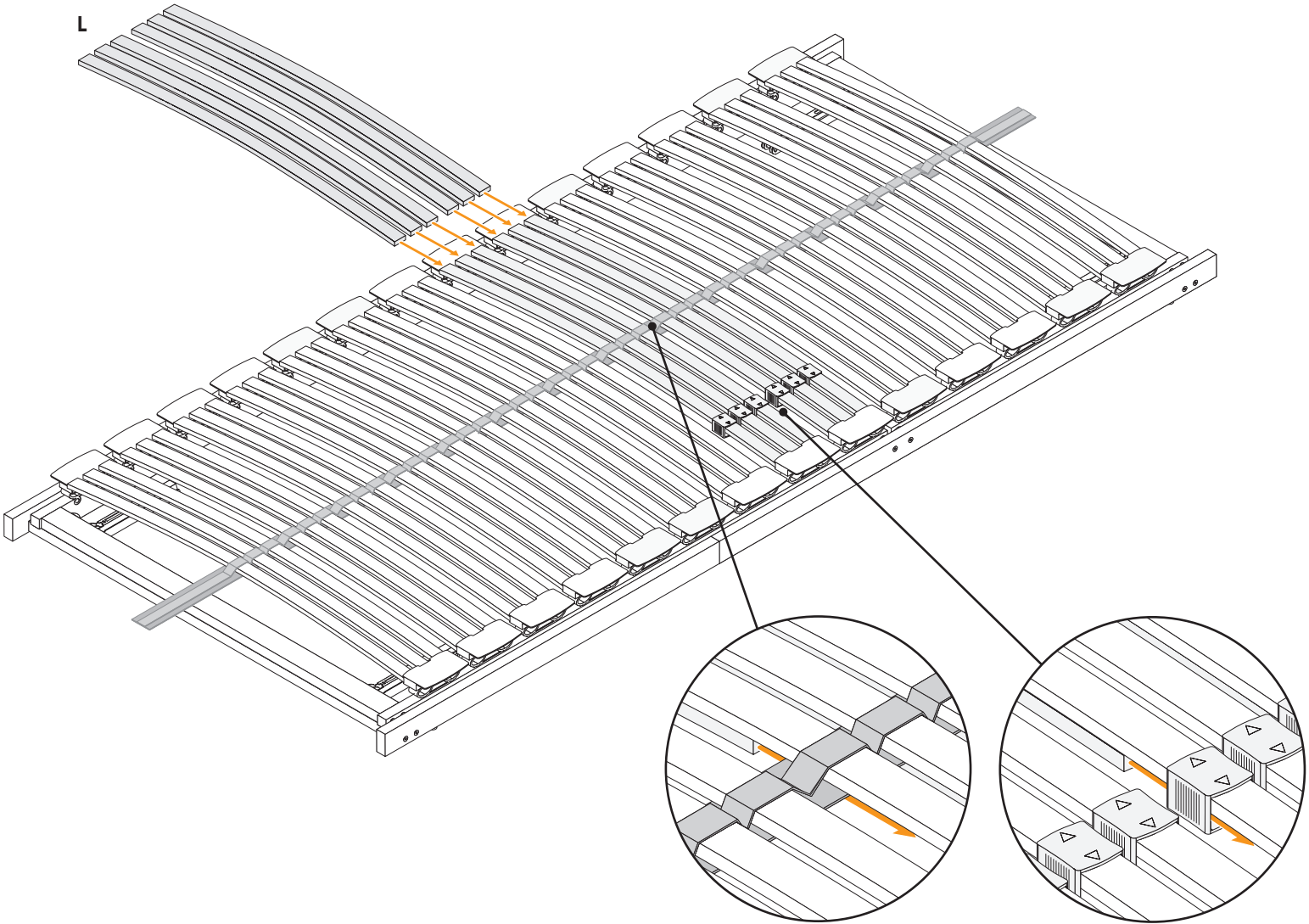

11

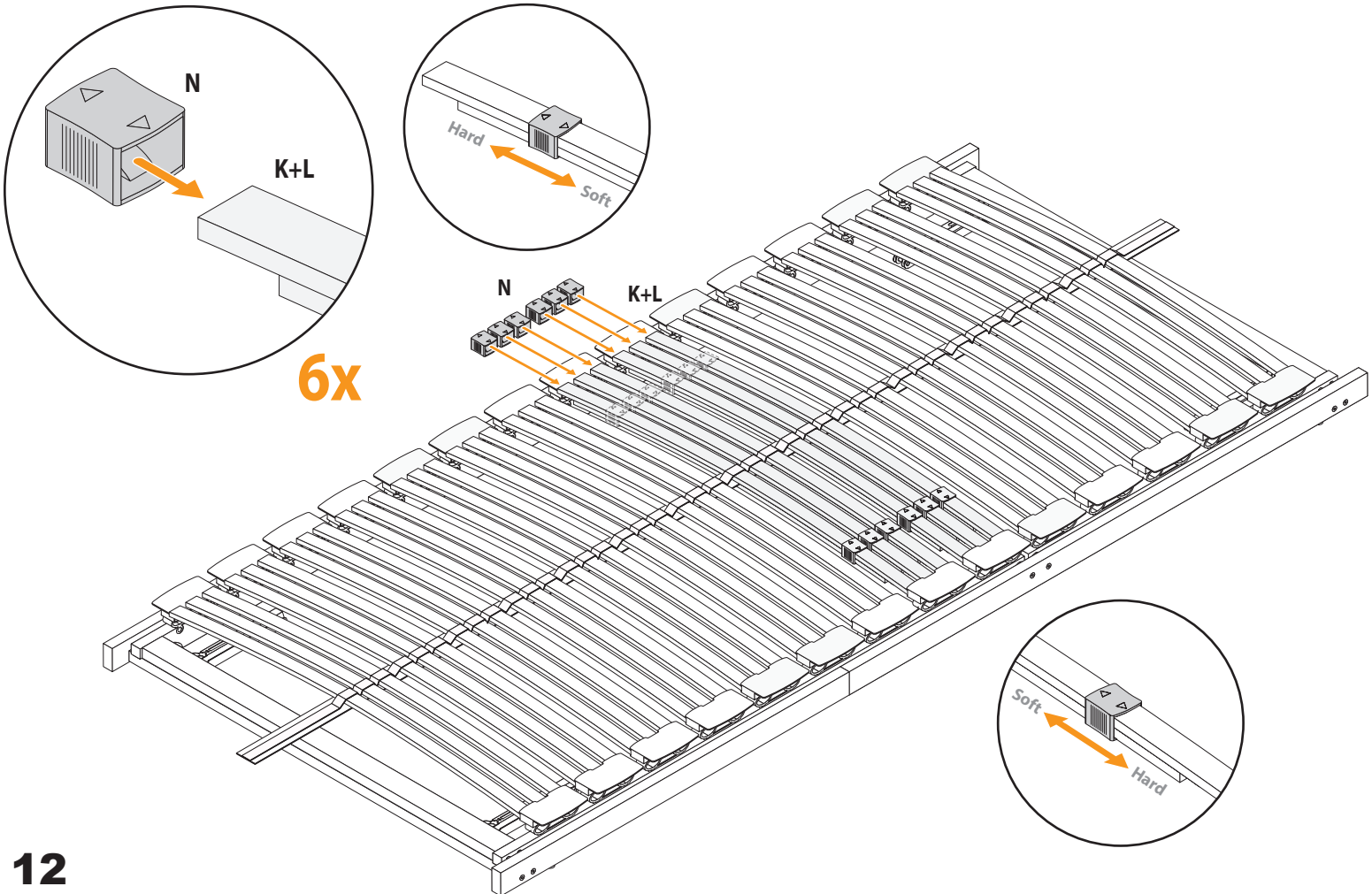

12

